

SCL 90-20 Gearbox

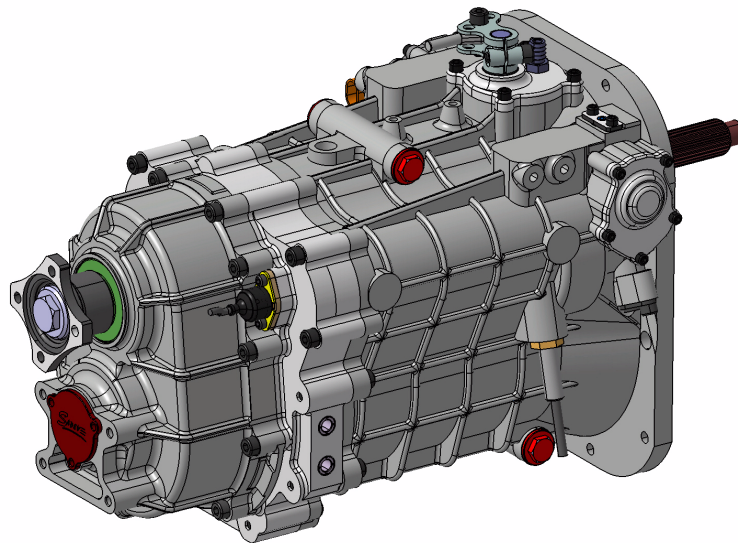

REFERENCE : SCL90-20



TECHNICAL DETAILS :

- 6 speed dog ring gearbox, with sequential gearing
- Variable ratios
- Maxi engine torque : 550 N.m (394 lbs/ft)
- Output (primary line)
- Specific aluminium housing



OPTIONAL :

- Gear lever with neutral reverse cable
- Gear display and switch for cut off system